



Marine

High speed engines for pleasure boats

MAN Engines





Contents

70 % of the earth is covered by water

Customer Benefits	4
Get out there and fish it with a MAN Engine	4
Get out there and enjoy it with a MAN Engine.	4
MAN Service: Competent and motivated	5
MAN Environmental Awareness: Future-oriented and ecofriendly	5
MAN Gold Standard: More safety and improved warranty	5

Description of engines

i6-730 and i6-800	7
V8-1000 and V8-1200	10
V12-1400 and V12-1550	13
V12-1650 and V12-1800	16
V12-1900	19



70 % of the earth is covered by water

With powers ranging from 730 to 1,900 hp, MAN yacht engines are Europe's number one. MAN engines impress with their extraordinary dynamics, their extreme running smoothness, economy and their trend-setting environmental friendliness. The finest from modern common rail.

Customer Benefits

- High tractive power even at low speeds
- Powerful acceleration and rapid reaction to commands
- High performance combined with low weight
- Compact, space-saving design
- High efficiency owing to low fuel consumption
- Low running costs and long service life
- Low emission values
- World-wide service network with rapid supply of spare parts

Get out there and fish it with a MAN Engine

That's a lot of water to cover, and a large amount of fish that comes along with it. Get those lines cast in every one of your "hot spots" with the power of MAN engines covering the distance. Our high-performance i6, V8 and V12 marine engines are just built for pleasure crafts, so you can sportfish in complete comfort and style while getting the fuel efficiency, clean running, smooth acceleration, quiet operation, and total reliability you expect. With a MAN on board, you're already starting off with a nice catch.

Get out there and enjoy it with a MAN Engine

Inline six-cylinder or V8/V12, with their innovative and dependable technology, MAN yacht engines open up new dimensions on the water. They develop enormous torque even at low revs – the kind of power you feel as a tingling down the spine. Breathtaking acceleration and high speeds are experiences to be savoured, yet our compact, lightweight power units are decidedly modest when it comes to fuel consumption. With a MAN on board, you're already starting off the day right.



Reason enough to enjoy life on the ocean with a MAN engine



MAN Service

Competent and motivated

MAN is there for you from the outset. Where qualified guidance is needed for the installation, our experts are at your side with advice and practical assistance. Of course you can always rely on our worldwide service network.

Qualified service centres provide you with fast and skilled servicing and repairs. Worldwide partners ensure a service network for marine engines. As you can see we are there whenever and wherever you need us.

MAN Environmental Awareness

Future-oriented and ecofriendly

At MAN, we attach very great importance indeed to eco-friendliness. Every day, our engineers do their utmost to develop eco-friendly engines which comply with current emission standards worldwide.

With their particularly low fuel consumption, MAN engines not only ensure high economy, but also protect our environment. And your ears: this means that the quiet yet very powerful engine makes every trip a unique experience. Real recreation – both for the customer and the environment.

MAN Gold Standard

More safety and improved warranty

The MAN Gold Standard® seal of quality is a perfectly matched overall concept which complies with excellent quality standards both in regards to installation as well as in regards to tuning of the MAN engine system. Close cooperation between ship-builder and the MAN engine specialists ensures that an engine compartment with optimum technical features is implemented. Improved technology and simplified access to the individual servicing points on the engine drastically speed up servicing work. This allows you to cut costs in the short term and maintain the value of the boat in the long term. This certificate of quality gives customers enhanced reliability and a longer warranty on the engine and its components.

If you want only the best, you should rely on the MAN Gold Standard®.

New: MAN Gold Standard Premium is available now. Please contact your local dealer concerning this 5-years factory warranty.



Light duty operation

Definition of application type

Characteristics

- Annual operating hours: $\leq 1,000$
- Percentage of time at full load: $\leq 20\%$
- Average load application: $\leq 50\%$

Typical applications

- Pleasure crafts
- Displacement yachts
- Sportfish boats



reddot design award
winner 2016



i6-730 and i6-800

Engine description

Characteristics

- Cylinders and arrangement: 6 cylinders in-line
- Operation mode: 4-stroke diesel engine, watercooled
- Turbocharging: Turbocharger with charge air intercooler and waste gate
- Number of valves: 4 valves per cylinder
- Fuel system: Common Rail direct fuel injection with electronic control
- Engine lubrication: Closed system with forced feeding, oil cooling and filtering
- Type of cooling: Heat exchanger with engine and seawater circuit
- Engine control: Electronic injection control (EDC)
Electronic engine monitoring including diagnostic unit
- Fuel: DIN EN 590

i6-730 and i6-800

Technical data

Technical features i6-730 and i6-800

Type designation		i6-730	i6-800
Displacement	l	12.42	12.42
Maximum output to DIN ISO 3046-1	kW (hp)	537 (730)	588 (800)
Rated speed	rpm	2,300	2,300
Maximum torque	Nm	2,450	2,674
at speed	rpm	1,300–2,100	1,400–2,000
Absolute fuel consumption at rated power ¹⁾	l/h	142	158
Classifiable		✓	–
Exhaust gas status		IMO Tier II, EPA Tier 3 RCD 2013/53/EC, RCD 94/25/EC, 97/68/EC	IMO Tier II, EPA Tier 3 ²⁾ , RCD 2013/53/EC, RCD 94/25/EC, 97/68/EC

1) Tolerance +5% according to DIN ISO 3046-1

2) for private use only

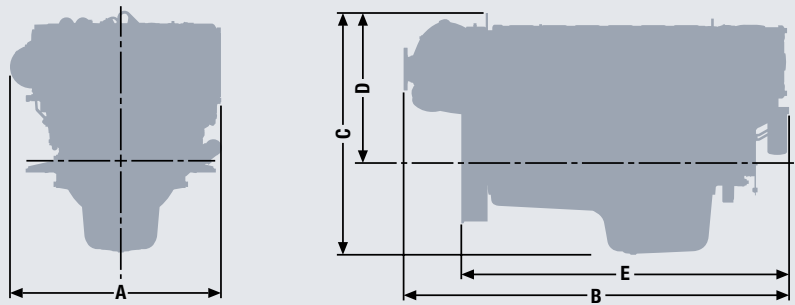

Dimensions i6-730 and i6-800

Type designation		i6-730/i6-800
A-Overall width	mm	986
B-Overall length	mm	1,795
C-Overall height – standard oil pan	mm	1,096
D-Top of engine to crankshaft centre	mm	674
E-Length of engine from front end to edge of flywheel housing	mm	1,527
Average weight of engine ready for installation (dry)	kg	1,215

For detailed examinations of installation dimensions, please order drawings from our factory.

i6-730 and i6-800

Power charts

i6-730

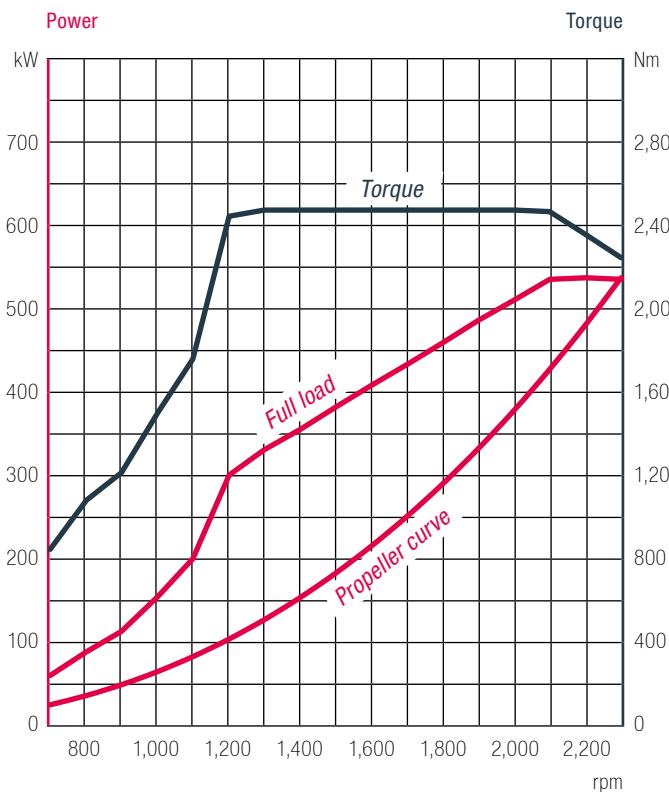

i6-800

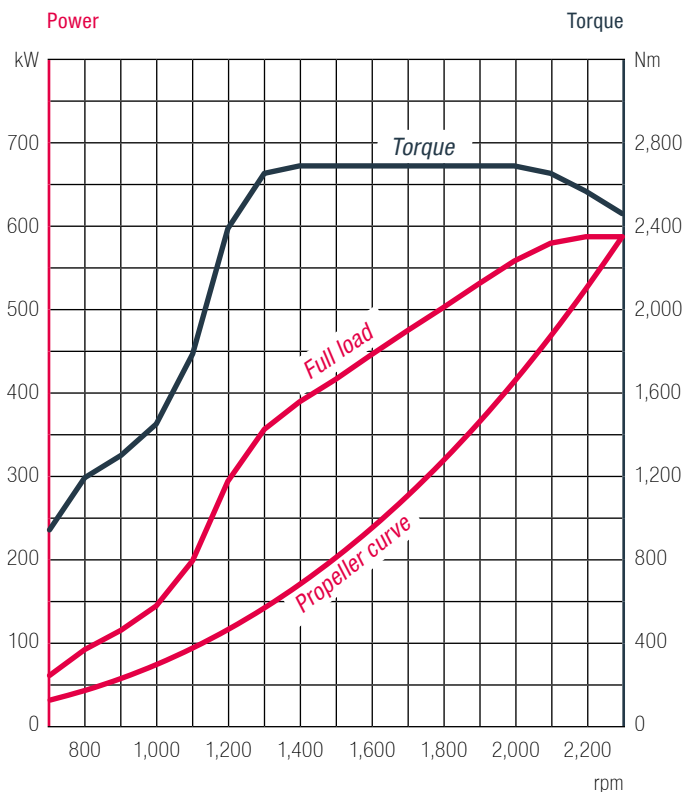

Absolute fuel consumption

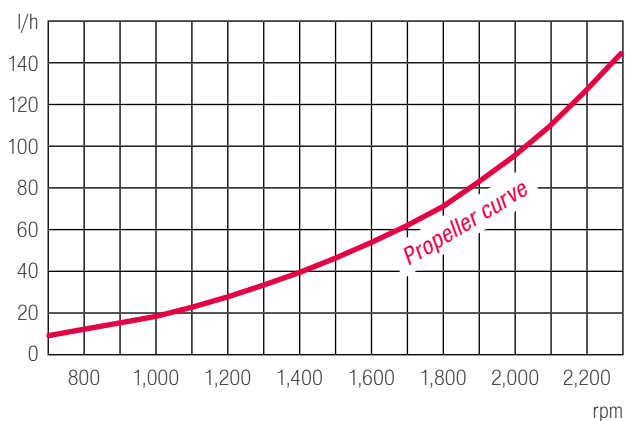

Absolute fuel consumption

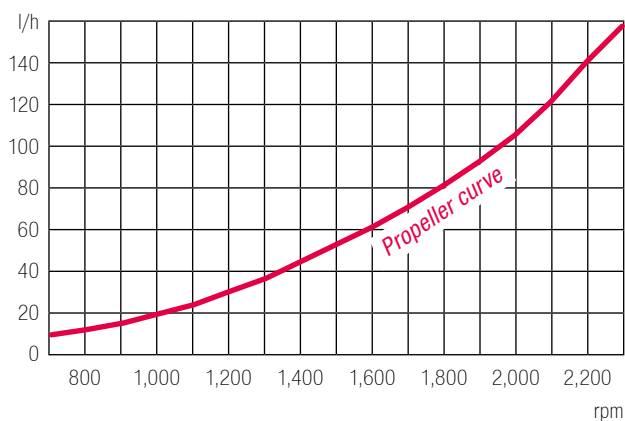



V8-1000 and V8-1200

Engine description

Characteristics

- Cylinders and arrangement: 8 cylinders in 90° V arrangement
- Operation mode: 4-stroke diesel engine, watercooled
- Turbocharging: Turbocharger with charge air intercooler and waste gate (1-stage: V8-1000, 2-stage: V8-1200)
- Number of valves: 4 valves per cylinder
- Fuel system: Common Rail direct fuel injection with electronic control
- Engine lubrication: Closed system with forced feeding, oil cooling and filtering
- Type of cooling: Plate heat exchanger, seawater cooled
- Engine control: Electronic injection control (EDC)
Electronic engine monitoring including diagnostic unit
- Fuel: DIN EN 590

V8-1000 and V8-1200

Technical data

Technical features V8-1000 and V8-1200

Type designation		V8-1000	V8-1200
Displacement	l	16.16	16.16
Maximum output to DIN ISO 3046-1	kW (hp)	735 (1,000)	882 (1,200)
Rated speed	rpm	2,300	2,300
Maximum torque	Nm	3,340	4,010
at speed	rpm	1,300–2,100	1,200–2,100
Absolute fuel consumption at rated power ¹⁾	l/h	199	240
Classifiable		–	–
Exhaust gas status		IMO Tier II, EPA Tier 3, RCD 2013/53/EC, RCD 94/25/EC, 97/68/EC	IMO Tier II, EPA Tier 3 ²⁾ , RCD 2013/53/EC, RCD 94/25/EC, 97/68/EC

1) Tolerance +5% according to DIN ISO 3046-1

2) for private use only

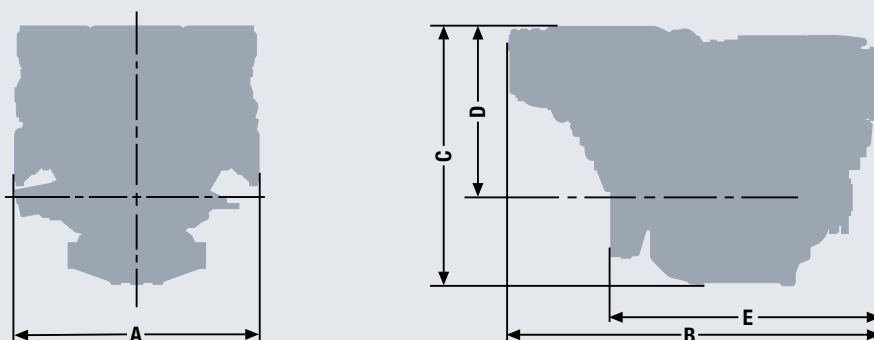

Dimensions V8-1000 and V8-1200

Type designation		V8-1000	V8-1200
A-Overall width	mm	1,153	1,153
B-Overall length	mm	1,745	1,745
C-Overall height	mm	1,177	1,222
D-Top of engine to crankshaft centre	mm	765	811
E-Length of engine from front end to edge of flywheel housing	mm	1,243	1,262
Average weight of engine ready for installation (dry)	kg	1,780	1,880

For detailed examinations of installation dimensions, please order drawings from our factory.

V8-1000 and V8-1200

Power charts

V8-1000

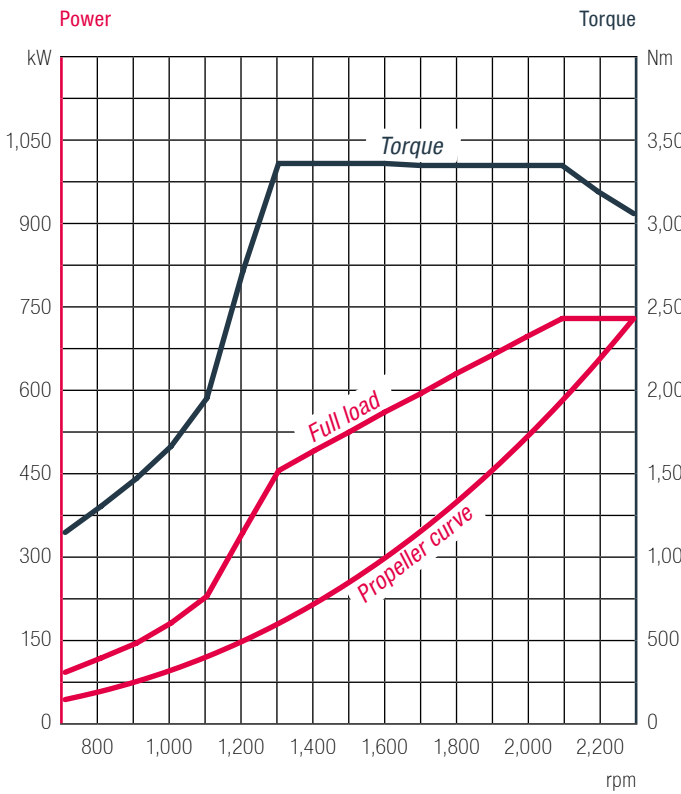

V8-1200

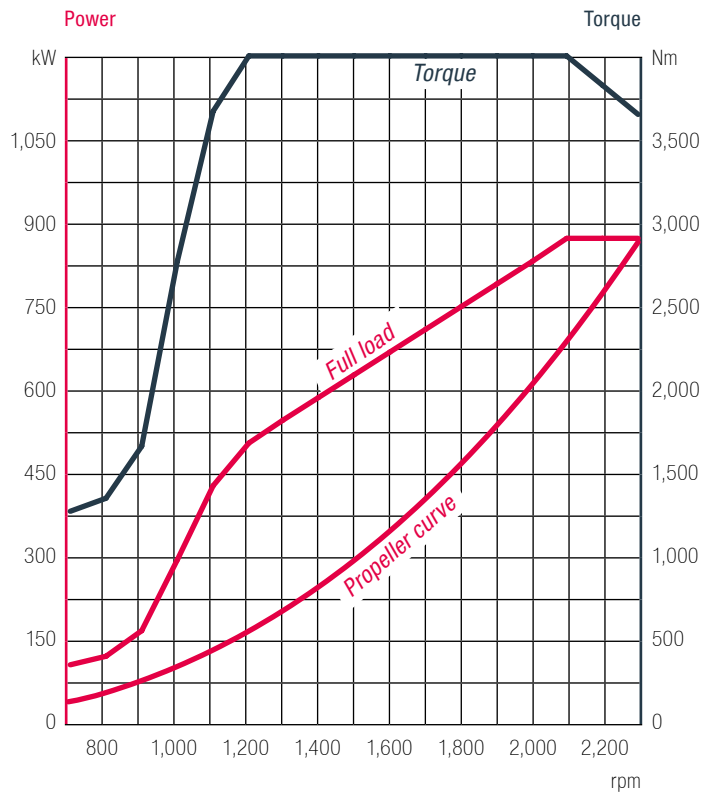

Absolute fuel consumption

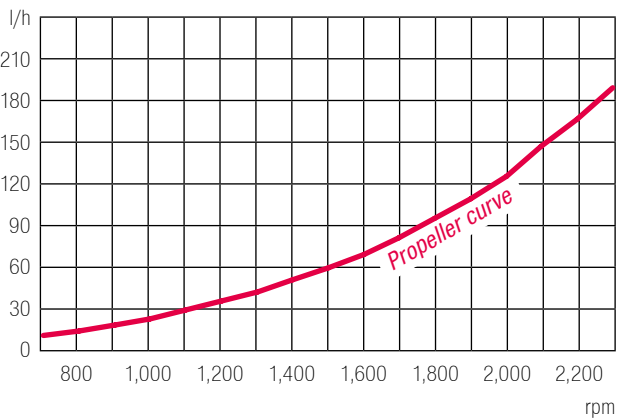

Absolute fuel consumption

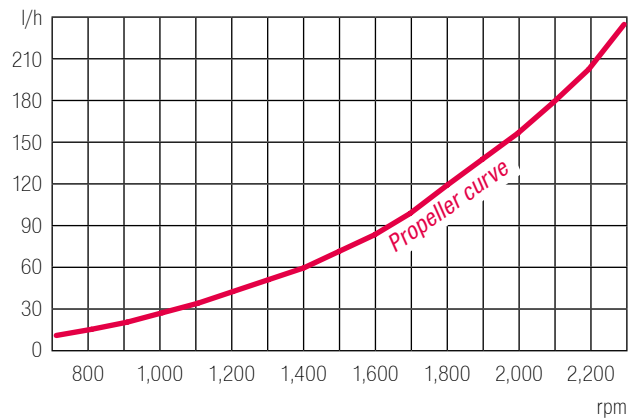



V12-1400 and V12-1550

Engine description

Characteristics

- Cylinders and arrangement: 12 cylinders in 90° V arrangement
- Operation mode: 4-stroke diesel engine, watercooled
- Turbocharging: Turbocharger with charge air intercooler and waste gate
- Number of valves: 4 valves per cylinder
- Fuel system: Common Rail direct fuel injection with electronic control
- Engine lubrication: Closed system with forced feeding, oil cooling and filtering
- Type of cooling: Plate heat exchanger, seawater cooled
- Engine control: Electronic injection control (EDC)
Electronic engine monitoring including diagnostic unit
- Fuel: DIN EN 590

V12-1400 and V12-1550

Technical data

Technical features V12-1400 and V12-1550

Type designation		V12-1400	V12-1550
Displacement	l	24.24	24.24
Maximum output to DIN ISO 3046-1	kW (hp)	1,029 (1,400)	1,140 (1,550)
Rated speed	rpm	2,300	2,300
Maximum torque	Nm	4,680	5,180
at speed	rpm	1,200–2,100	1,200–2,100
Absolute fuel consumption at rated power ¹⁾	l/h	267	299
Classifiable		✓	–
Exhaust gas status		IMO Tier II, EPA Tier 3 ²⁾ , RCD 2013/53/EC, RCD 94/25/EC, 97/68/EC	IMO Tier II, EPA Tier 3 ²⁾ , RCD 2013/53/EC, RCD 94/25/EC, 97/68/EC

1) Tolerance +5% according to DIN ISO 3046-1

2) for private use only

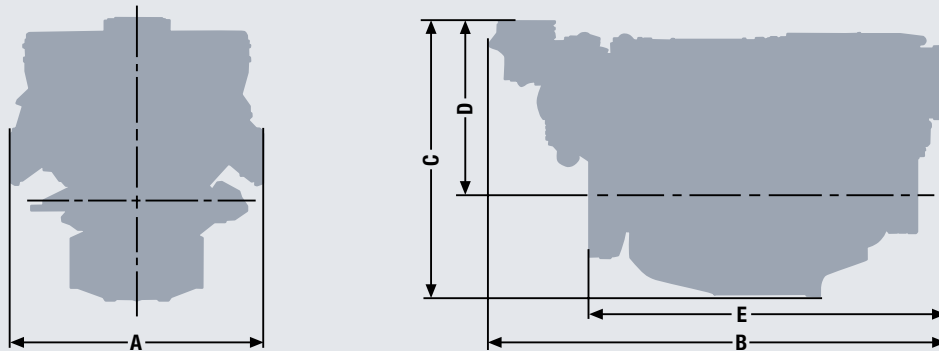

Dimensions V12-1400 and V12-1550

Type designation		V12-1400/1550
A-Overall width	mm	1,153
B-Overall length	mm	2,130
C-Overall height	mm	1,230
D-Top of engine to crankshaft centre	mm	765
E-Length of engine from front end to edge of flywheel housing	mm	1,630
Average weight of engine ready for installation (dry)	kg	2,270

For detailed examinations of installation dimensions, please order drawings from our factory.

V12-1400 and V12-1550

Power charts

V12-1400

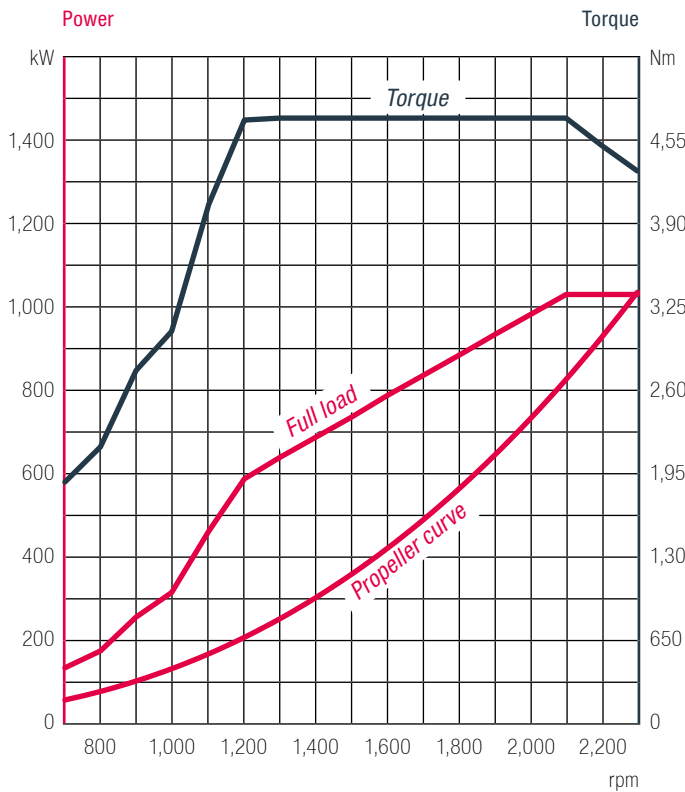

V12-1550

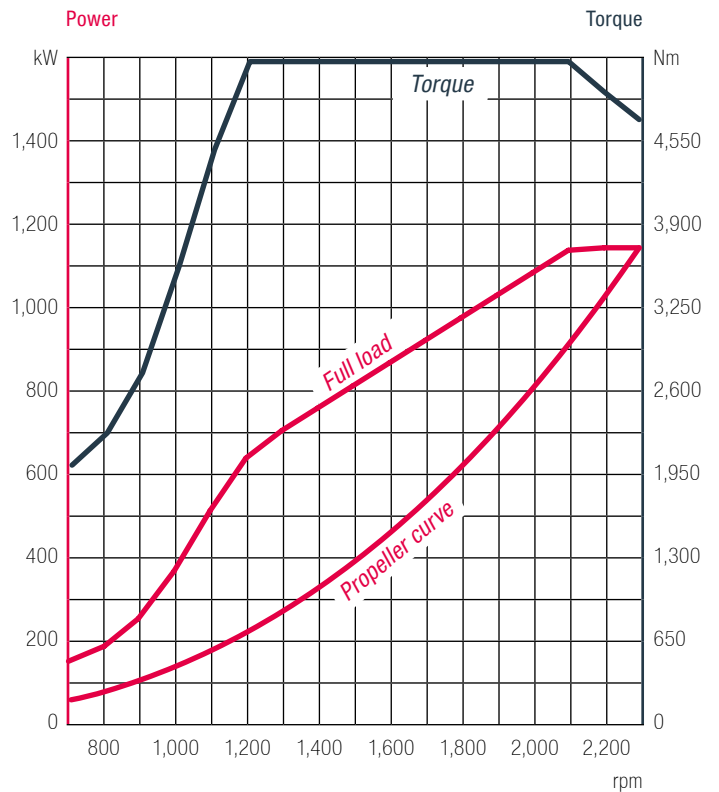

Absolute fuel consumption

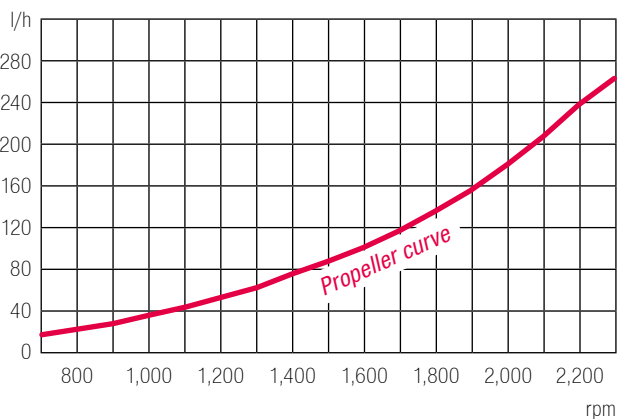

Absolute fuel consumption

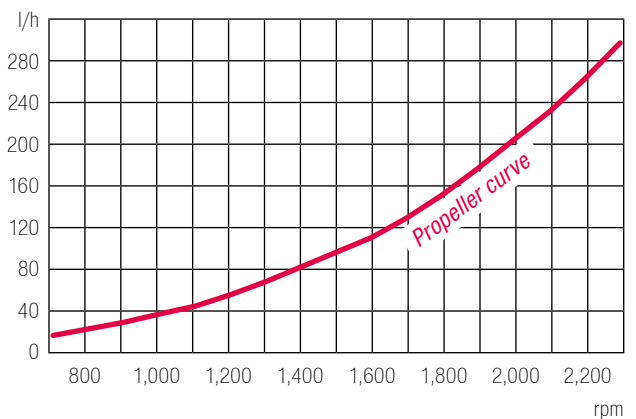

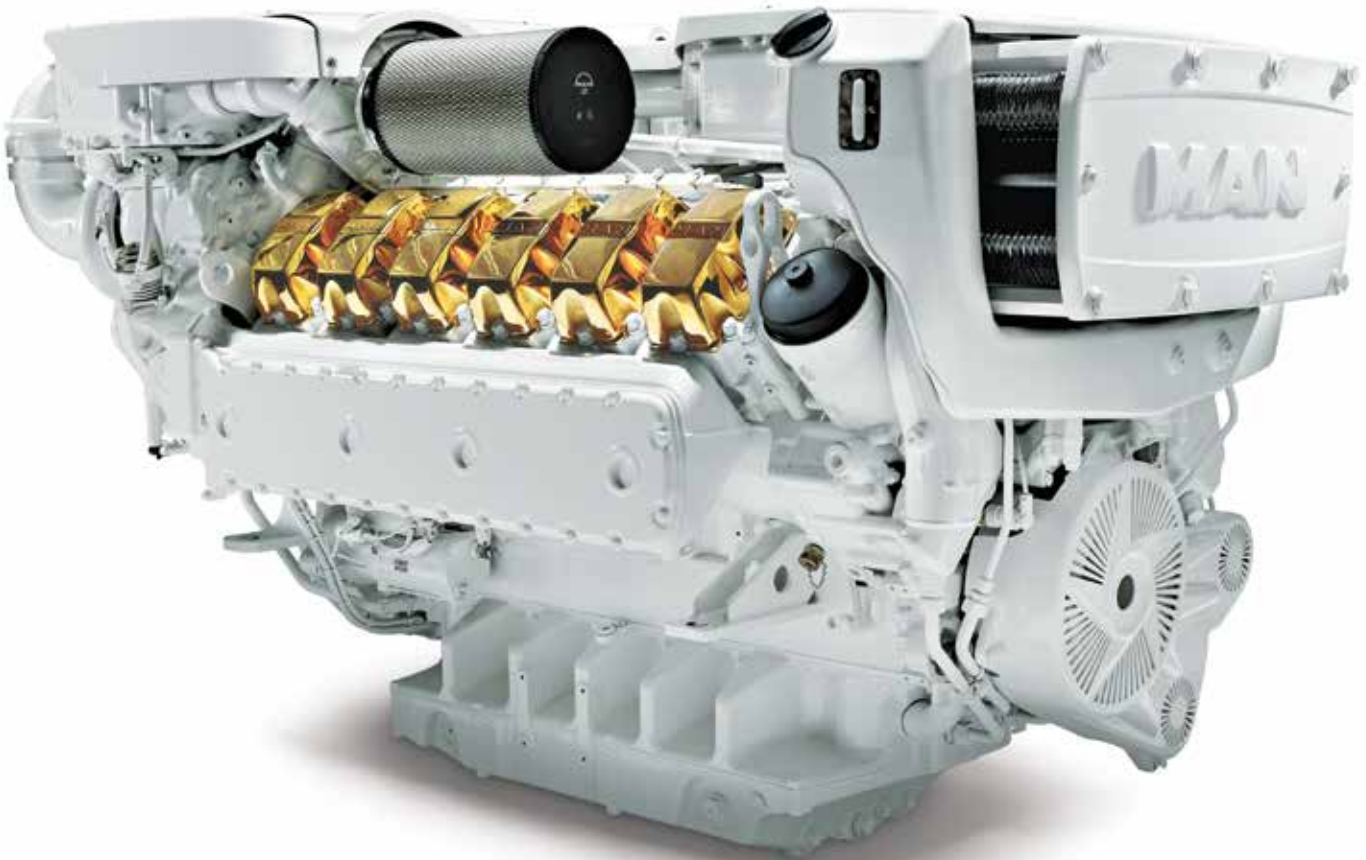

V12-1650 and V12-1800

Engine description

Characteristics

- Cylinders and arrangement: 12 cylinders in 90° V arrangement
- Operation mode: 4-stroke diesel engine, watercooled
- Turbocharging: 2-stage turbocharger with charge air intercooler and waste gate
- Number of valves: 4 valves per cylinder
- Fuel system: Common Rail direct fuel injection with electronic control
- Engine lubrication: Closed system with forced feeding, oil cooling and filtering
- Type of cooling: Plate heat exchanger, seawater cooled
- Engine control: Electronic injection control (EDC)
Electronic engine monitoring including diagnostic unit
- Fuel: DIN EN 590

V12-1650 and V12-1800

Technical data

Technical features V12-1650 and V12-1800

Type designation		V12-1650	V12-1800
Displacement	l	24.24	24.24
Maximum output to DIN ISO 3046-1	kW (hp)	1,213 (1,650)	1,324 (1,800)
Rated speed	rpm	2,300	2,300
Maximum torque	Nm	5,510	6,010
at speed	rpm	1,200–2,100	1,200–2,100
Absolute fuel consumption at rated power ¹⁾	l/h	323	351
Classifiable		✓	–
Exhaust gas status		IMO Tier II, EPA Tier 3, RCD 2013/53/EC, 97/68/EC	IMO Tier II, EPA Tier 3 ²⁾ , RCD 2013/53/EC, RCD 94/25/EC, 97/68/EC

1) Tolerance +5% according to DIN ISO 3046-1

2) for private use only

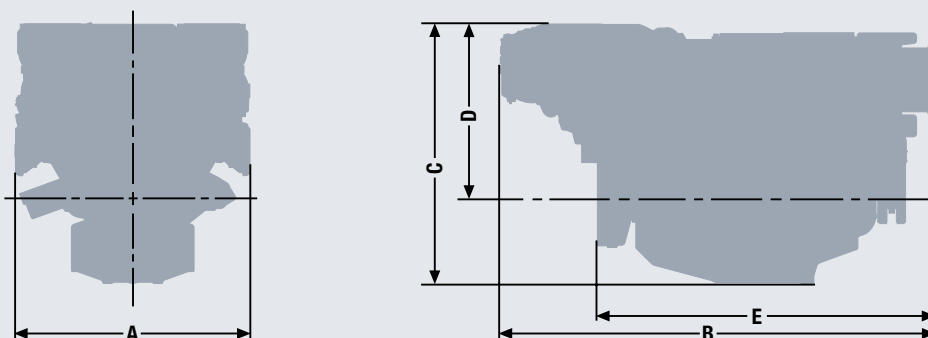

Dimensions V12-1650 and V12-1800

Type designation		V12-1650/1800
A-Overall width	mm	1,153
B-Overall length	mm	2,139
C-Overall height	mm	1,275
D-Top of engine to crankshaft centre	mm	808
E-Length of engine from front end to edge of flywheel housing	mm	1,658
Average weight of engine ready for installation (dry)	kg	2,380

For detailed examinations of installation dimensions, please order drawings from our factory.

V12-1650 and V12-1800

Power charts

V12-1650

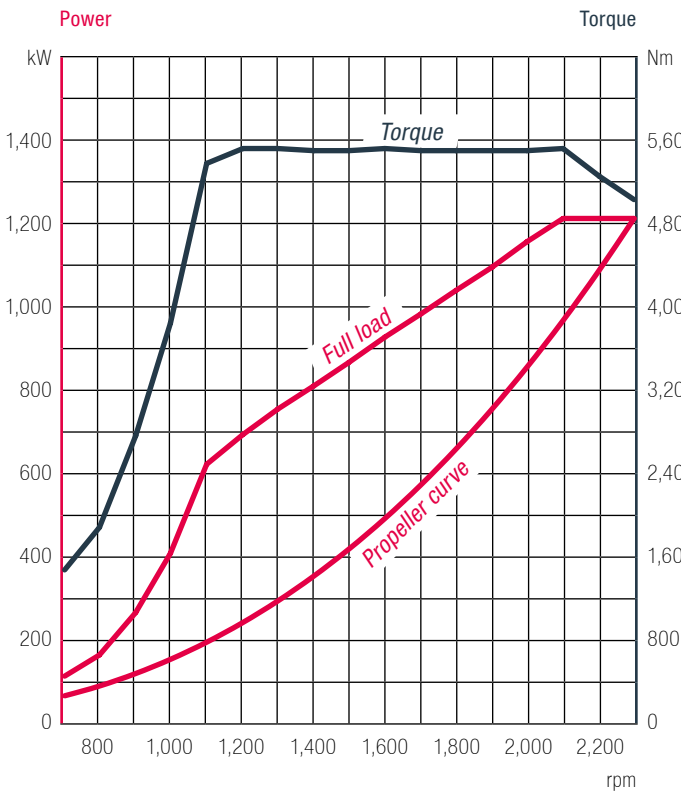

V12-1800

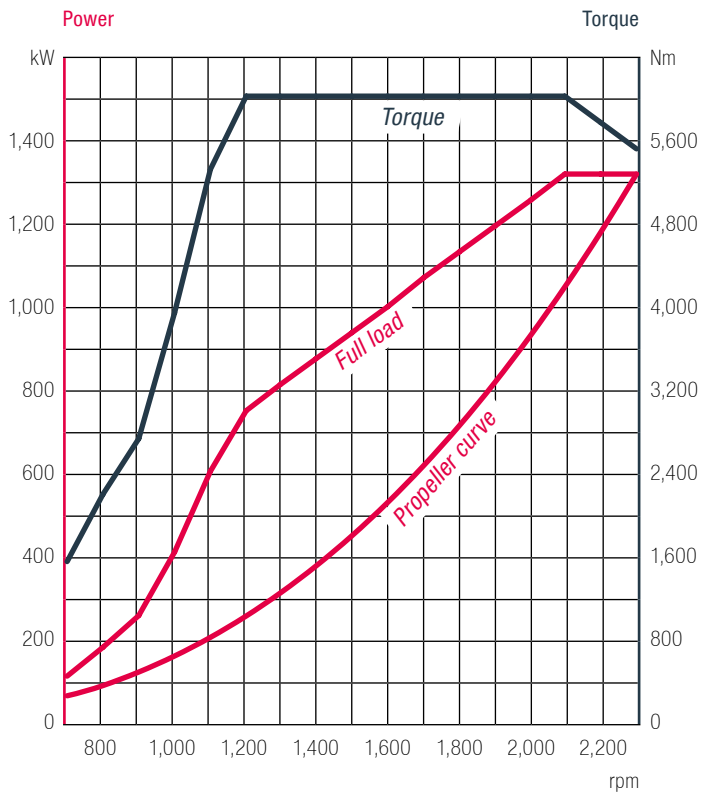

Absolute fuel consumption

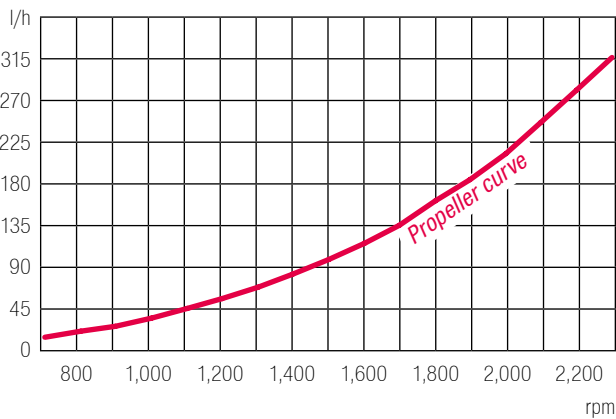

Absolute fuel consumption

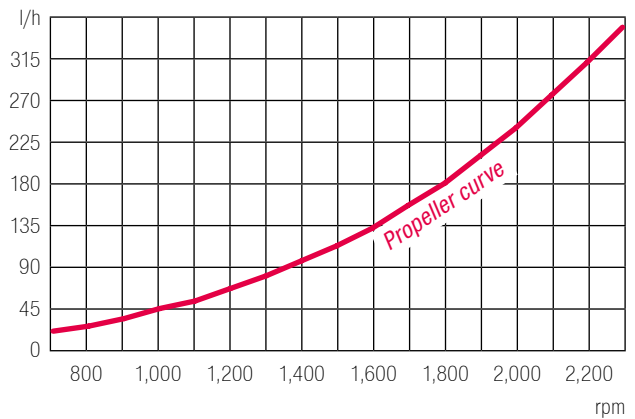



V12-1900

Engine description

Characteristics

- Cylinders and arrangement: 12 cylinders in 90° V arrangement
- Operation mode: 4-stroke diesel engine, watercooled
- Turbocharging: Turbocharger with charge air intercooler and waste gate
- Number of valves: 4 valves per cylinder
- Fuel system: Common Rail direct fuel injection with electronic control
- Engine lubrication: Closed system with forced feeding, oil cooling and filtering
- Type of cooling: Plate heat exchanger, seawater cooled
- Engine control: Electronic injection control (EDC)
Electronic engine monitoring including diagnostic unit
- Fuel: DIN EN 590

V12-1900

Technical data

Technical features V12-1900

Type designation	V12-1900	
Displacement	l	24.24
Maximum output to DIN ISO 3046-1	kW (hp)	1,397 (1,900)
Rated speed	rpm	2,300
Maximum torque	Nm	6,220
at speed	rpm	1,200–2,100
Absolute fuel consumption at rated power ¹⁾	l/h	373
Classifiable		–
Exhaust gas status		IMO Tier II, EPA Tier 3 ²⁾ , RCD 2013/53/EC, RCD 94/25/EC, 97/68/EC

1) Tolerance +5% according to DIN ISO 3046-1
2) for private use only

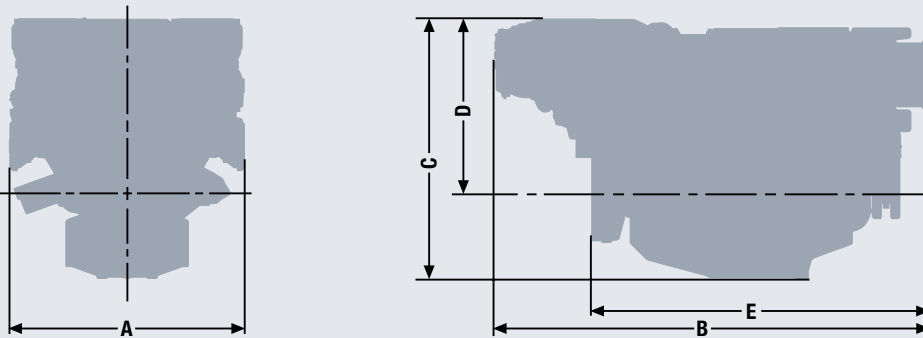

Dimensions V12-1900

Type designation	V12-1900	
A-Overall width	mm	1,153
B-Overall length	mm	2,139
C-Overall height	mm	1,272
D-Top of engine to crankshaft centre	mm	808
E-Length of engine from front end to edge of flywheel housing	mm	1,658
Average weight of engine ready for installation (dry)	kg	2,380

For detailed examinations of installation dimensions, please order drawings from our factory.

V12-1900

Power charts

V12-1900

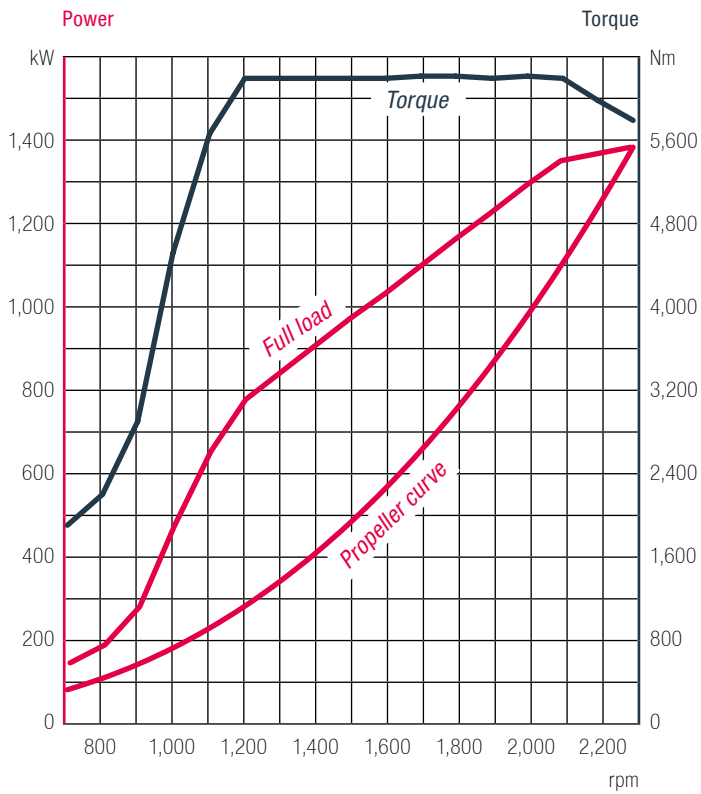

Absolute fuel consumption

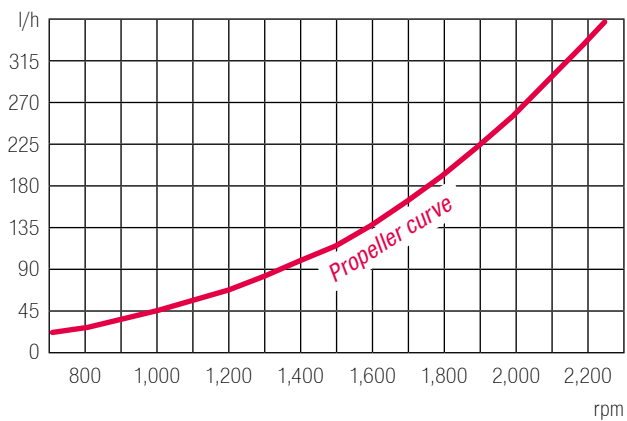

Notes

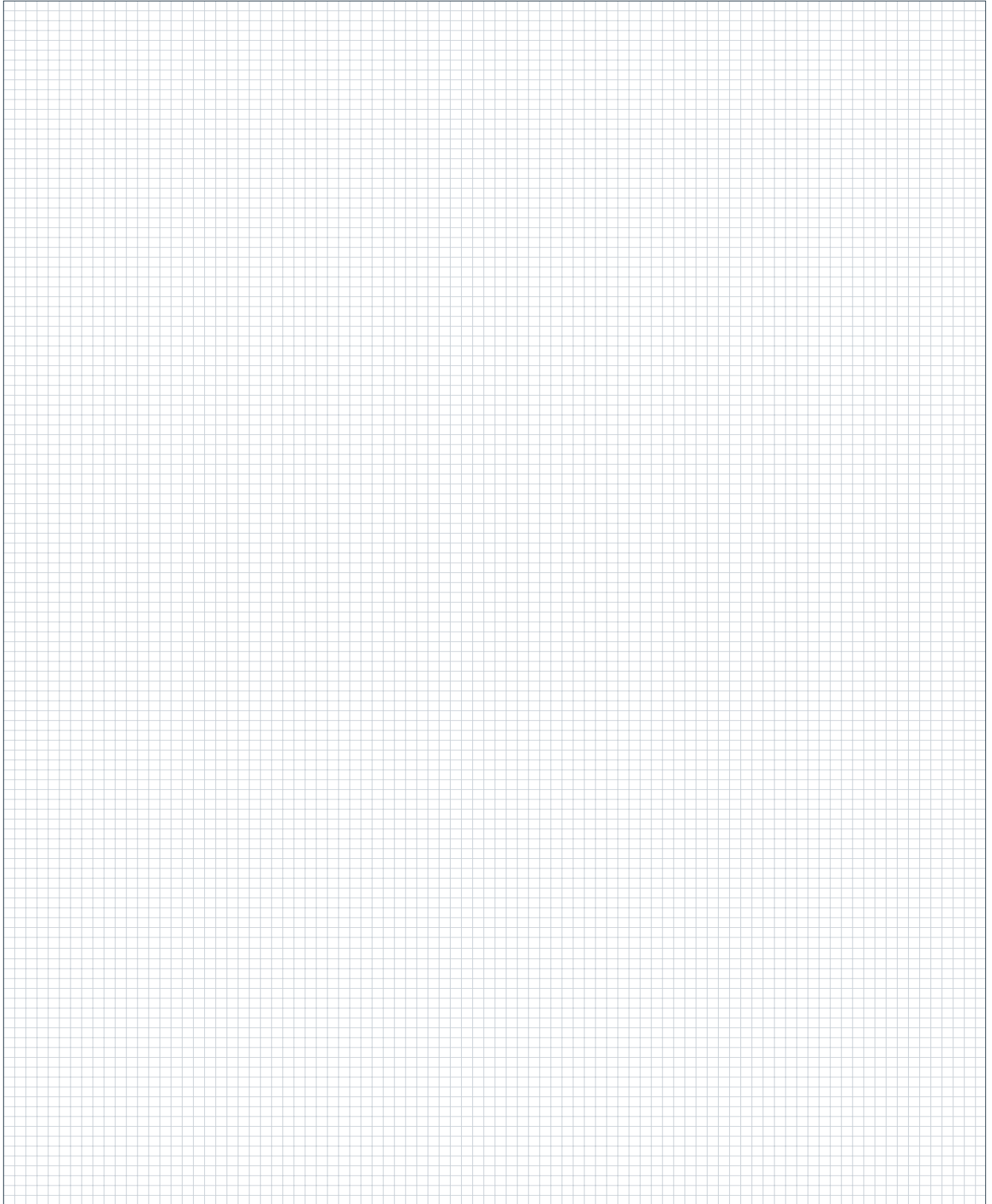

Engine range

Light duty

6 inline and V8 engines

Characteristics	Unit	i6		V8	
Type designation		730	800	1000	1200
Arrangement and number of cylinders		R6	R6	V8	V8
Nominal rating	hp	730	800	1,000	1,200
Maximum torque	Nm	2,450	2,674	3,340	4,010
Engine classifiable		✓	-	-	-
Rated speed	rpm	2,300	2,300	2,300	2,300
Fuel consumption	l/h	142	158	199	240
Bore/Stroke	mm	126/166	126/166	128/157	128/157
Displacement	l	12.42	12.42	16.16	16.16
Length of engine from front end to edge of flywheel housing	mm	1,527	1,527	1,243	1,262
Width	mm	986	986	1,153	1,153
Height	mm	1,096	1,096	1,177	1,222
Dry weight	kg	1,215	1,215	1,780	1,880
Exhaust gas status		A	B	A	B

V12 engines

Characteristics	Unit	V12				
Type designation		1400	1550	1650	1800	1900
Arrangement and number of cylinders		V8	V12	V12	V12	V12
Nominal rating	hp	1,400	1,550	1,650	1,800	1,900
Maximum torque	Nm	4,680	5,180	5,510	6,020	6,220
Engine classifiable		✓	-	✓	-	-
Rated speed	rpm	2,300	2,300	2,300	2,300	2,300
Fuel consumption	l/h	267	299	323	351	373
Bore/Stroke	mm	128/157	128/157	128/157	128/157	128/157
Displacement	l	24.24	24.24	24.24	24.24	24.24
Length of engine from front end to edge of flywheel housing	mm	1,630	1,630	1,658	1,658	1,658
Width	mm	1,153	1,153	1,153	1,153	1,153
Height	mm	1,230	1,230	1,275	1,275	1,275
Dry weight	kg	2,270	2,270	2,380	2,380	2,380
Exhaust gas status		B	B	C	B	B

- A IMO Tier II, EPA Tier 3, RCD 2013/53/EC, RCD 94/25/EC, 97/68/EC
- B IMO Tier II, EPA Tier 3 for private use only, RCD 2013/53/EC, RCD 94/25/EC, 97/68/EC
- C IMO Tier II, EPA Tier 3, RCD2013/53/EC, 97/68/EC

Copyright

Credits and Photography

- Front cover and page 4 right: Image courtesy of Princess Yachts international plc
- Page 2 and 5: Benetti shipyard archive and photographer Giuliano Sargentini (Benetti Tradition 108', page 2), photographer Alberto Cocchi (Benetti Classic 121' FF1, page 5)
- Page 3: Image courtesy of Fotolia by Adobe and photographer FrankU
- Page 4 left: Image courtesy of Riviera Australia Pty Ltd
- Page 6: Image courtesy of Riva Yacht – a Ferretti Group brand

MAN Truck & Bus AG

Vogelweiherstr. 33
90441 Nuremberg, Germany
man-engines@man.eu
www.man-engines.com

D 114.601 · mu 08164 · Printed in Germany

All data provided in this document is non-binding. This data serves informational purposes only and is especially not guaranteed in any way. Depending upon the subsequent specific individual projects, the relevant data may be subject to changes and will be assessed and determined individually for each project. This will depend on the particular characteristics of each individual project, especially specific site and operational conditions.

MAN Truck & Bus – a member of the MAN Group